

next generation margarine packaging; 08

the LÄTTA taste development die LÄTTA Geschmacksentfaltung

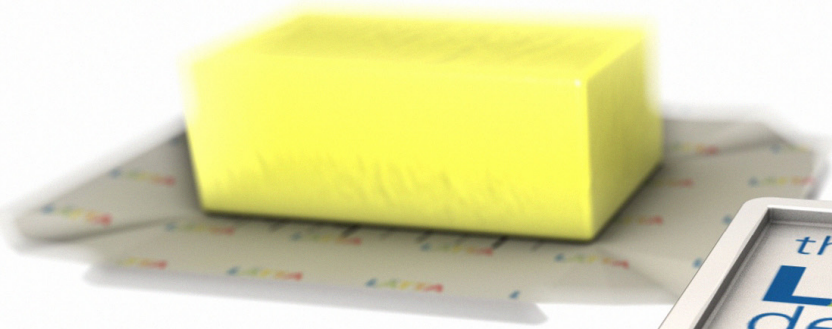

by this foldable packaging concept (inspired by japanese origami), a new and interesting kind of presentation on the table and also in stores arises. in the open state you reach the margarine well from all sides and the flat case turn into a showroom for the margarine. this is an easy and intuitively comfortable way to use margarine.



.... grab this extended edge to open

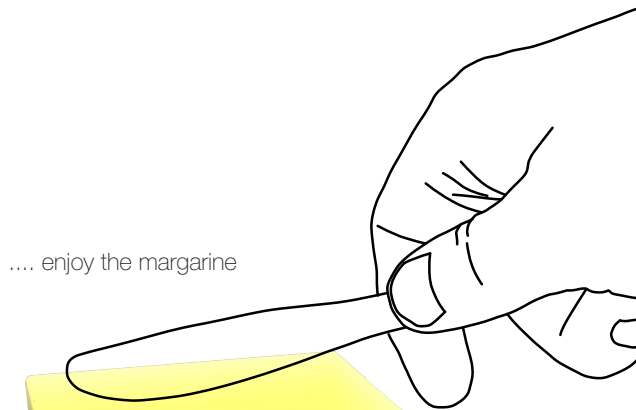

.... enjoy the margarine

...fold the 4 sides down like this.

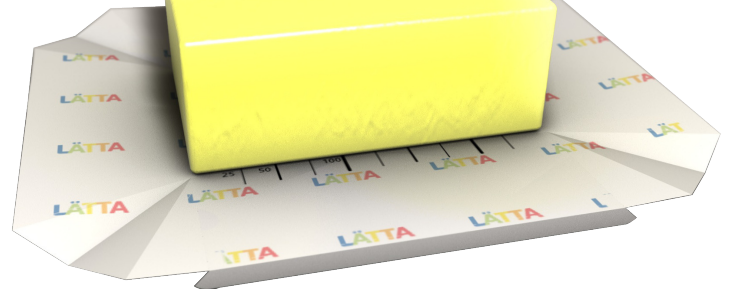
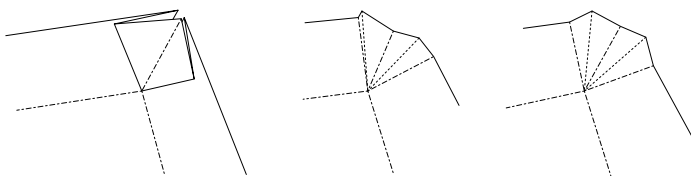

the LÄTTA taste development

die LÄTTA Geschmacksentfaltung

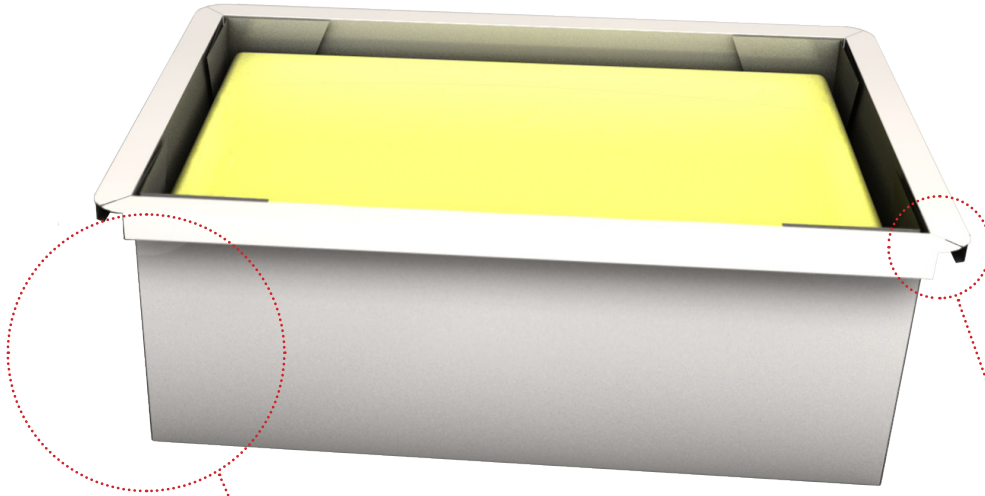

case template - right upper edge

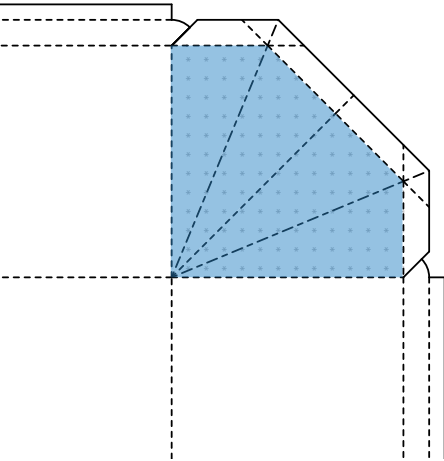

a closed collar runs around the case for good lid fitting

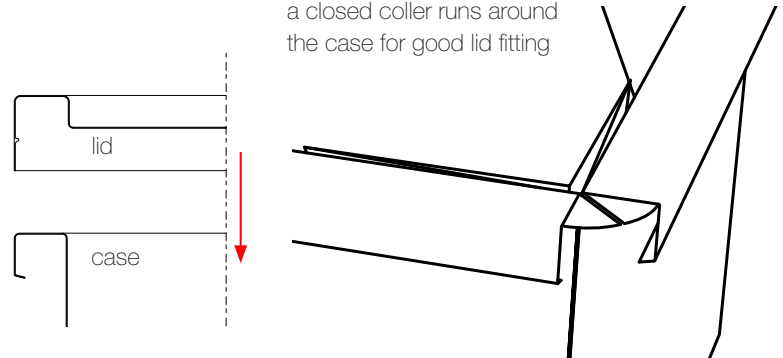

avoid cutting edges...
... crimp over to avoid fat penetration!

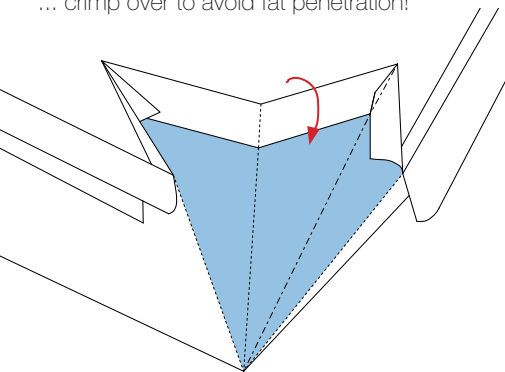

in empty state the case is flat...
in full state they are stackable
like this...

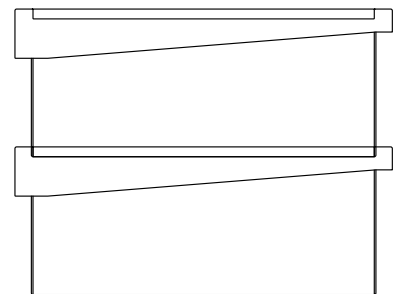

- materials
- tube - laminated cardboard or polypropylene
 - lid - polypropylene